

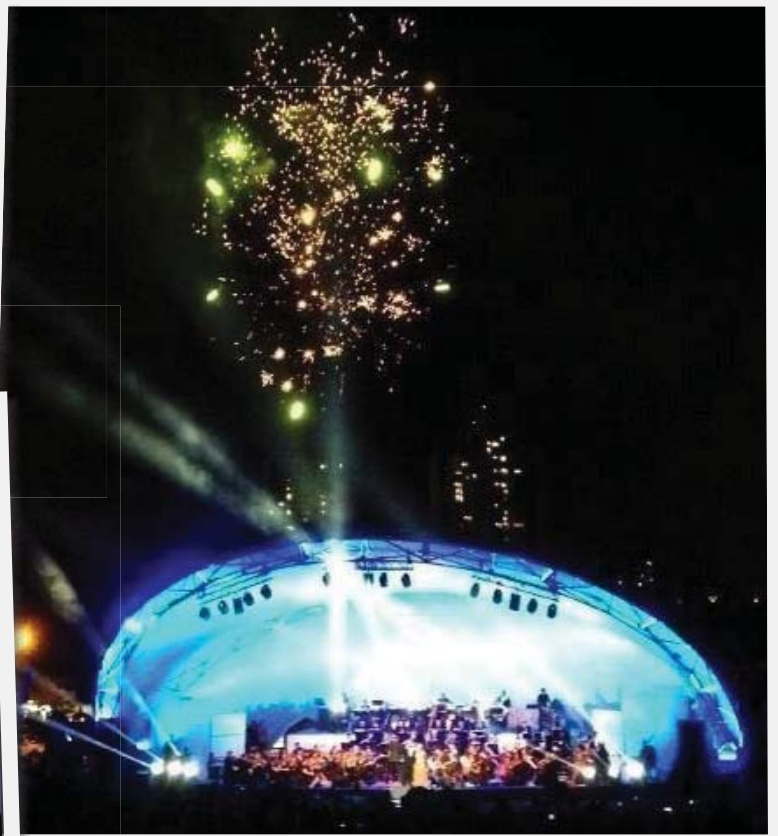

Arabesque

Stagecovers

Elegant, Dramatic, Beautiful
STRONG and STABLE



ARABESQUE STAGECOVER

An Arabesque Stagecover, with its dramatic curves and distinctive design, creates a striking backdrop for any outdoor concert. It is renowned for its superb acoustic projection and excellent sight lines.

The Arabesque with its strong frame is available in various sizes. The clearspan interior is able to accommodate most stage dimensions for groups from a small handful of entertainers to a full orchestra.

By adding an end panel, the Arabesque Stagecover converts quickly and easily to an Arabesque Theatre.

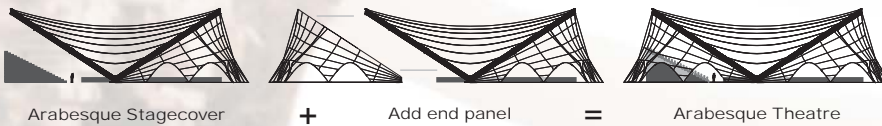

DISTINCTIVE

Unique, portable, outdoor stagecovers with graceful dramatic lines in various attractive colours.

VERSATILE / FLEXIBLE

The Arabesque patented framing adjusts to fit a range of ground conditions and stage widths.

EASY TO ASSEMBLE

All assembly is done at ground level. Parts are interchangeable.

CLEARSPAN FRAME

The arch frame of curved interchangeable trusses provides an obstruction-free interior.

SUPERB ACOUSTICS

The Arabesque double curved and tensioned cover delivers remarkably clear sound projection and excellent sight lines.

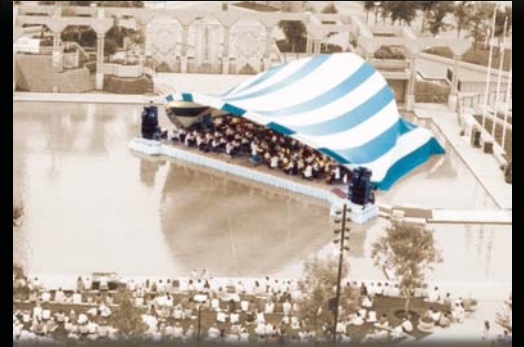
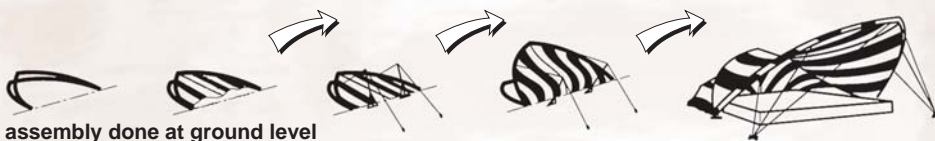

WSSL ARABESQUE STAGECOVER

SA 22



- 30' deep x 24' wide x 10' high, nominal
- Set up on the stage (with anchorage to the ground)
- Set up approximately 1 hour with 2 people
- Shipping: weight 500 lbs; dimension 1' x 2' x 12'
- All assembly done at ground level

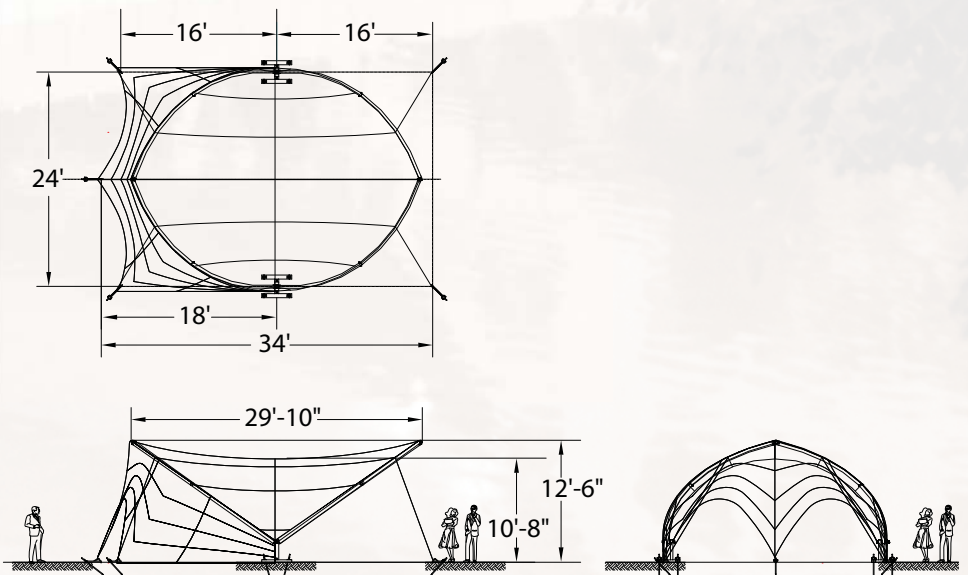

WSSL ARABESQUE STAGECOVER

SA 34



- 49' deep x 34' wide x 18' high, nominal
- Accommodates stages as large as 40' x 25' x 24"
- Set up approximately 2-3 hours with 4 people
- Shipping: weight 1,400 lbs; dimension 2' x 3' x 15'
- All assembly done at ground level

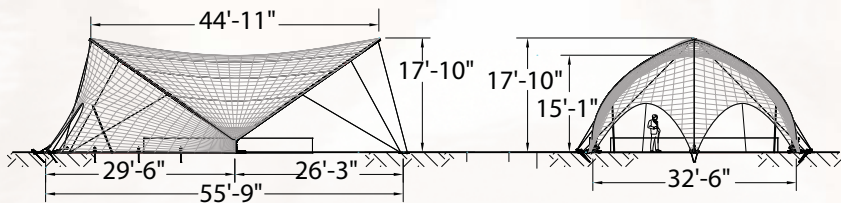
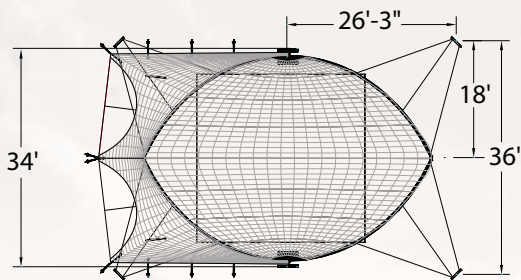

WSSL ARABESQUE STAGECOVER

SA 41



- 65' deep x 41' wide x 18' high, nominal
- Accommodates stages 35' wide by 40' deep
- Set up approximately 3-4 hours with 4 people
- Shipping: weight 2,000 lbs; dimension 3' x 4' x 13'
- All assembly done at ground level

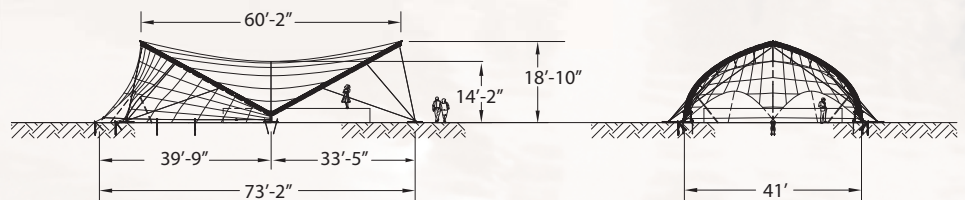
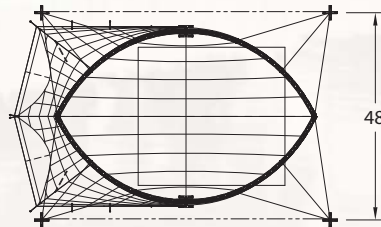

WSSL ARABESQUE STAGECOVER

SA 56



- 81' deep x 56' wide x 25' high, nominal
- Accommodates stages as large as 48' x 48'
- Set-up approximately 4-6 hours with 4 men
- Shipping: weight 3,100 lbs; dimension 3' x 8' x 18'
- All assembly done at ground level

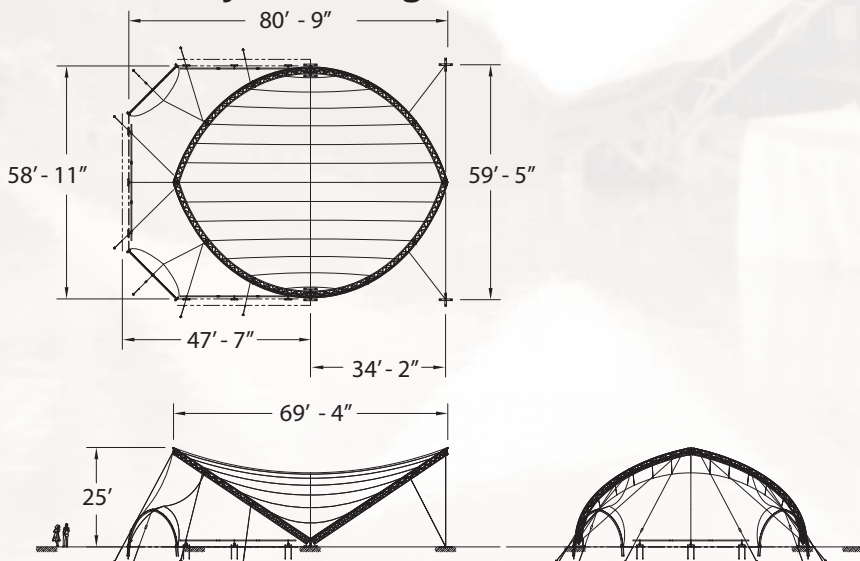

WSSL ARABESQUE STAGECOVER

SA 80



- 71' deep x 80' wide x 29' high, nominal
- Accommodates stages as large as 60' x 50'
- Set up approximately 10 hours with 6 people
- Shipping: weight 7,500 lbs; dimension 5' x 8' x 10'
- All assembly done at ground level

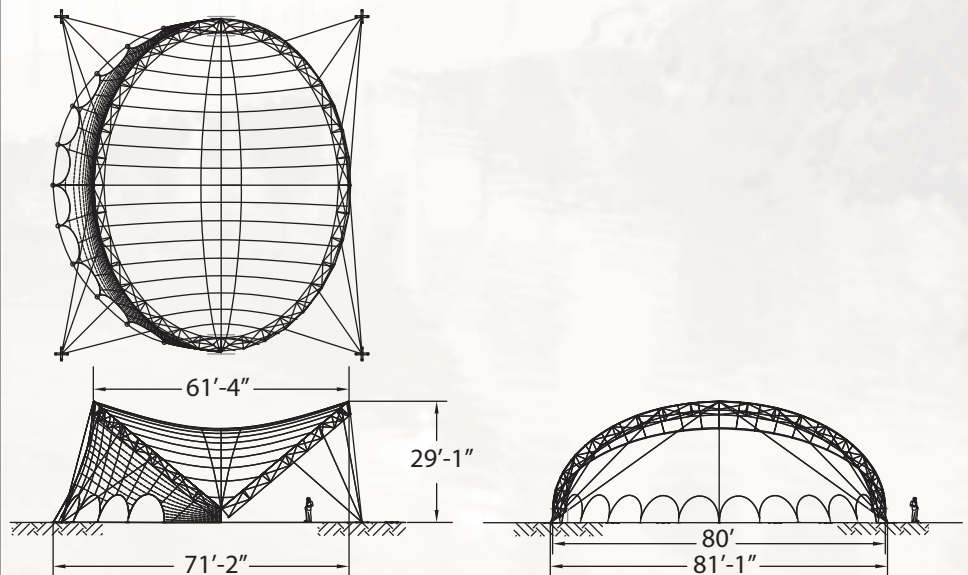

WSSL TENTS

Warner Shelter Systems Limited creates fabric-clad structures to suit virtually every purpose, from special events, trade shows, catering and outdoor concerts to warehousing and industrial use. Our award-winning tents are user friendly, durable and set-up quickly.

We have earned a reputation for providing a high level of service to customers since 1970. It is a pleasure to serve you. Please contact us for further information.

Other WSSL tents & structures



PEAK MARQUEE TENT

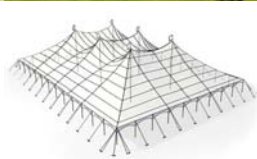

PEAK POLE TENT



MODULAR CLEARSPAN BUILDING



ARABESQUE THEATRE TENT



DOME STAGECOVER



GIGA-SPAN STRUCTURES



TENT - C - CAN



WSSL GARAGE

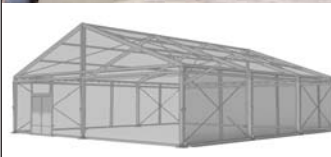

TENT - X - SPAN



Warner Shelter Systems Limited

Tents and Fabric-Clad Structures

9811 - 44th Street, SE, Calgary, Alberta, Canada T2C 2P7
 Phone: (403) 279-7662 or (800) 661-6155; Fax: (403) 236-2633
 Website: www.wssl.com • E-mail: warner@wssl.com

