

# PEAK MARQUEE™ TENT MQ10H

#11032: Frame Assembly with Aluminum Tubes  
#11036: Frame Assembly with Steel Tubes

## ANCHOR LOAD GUIDE

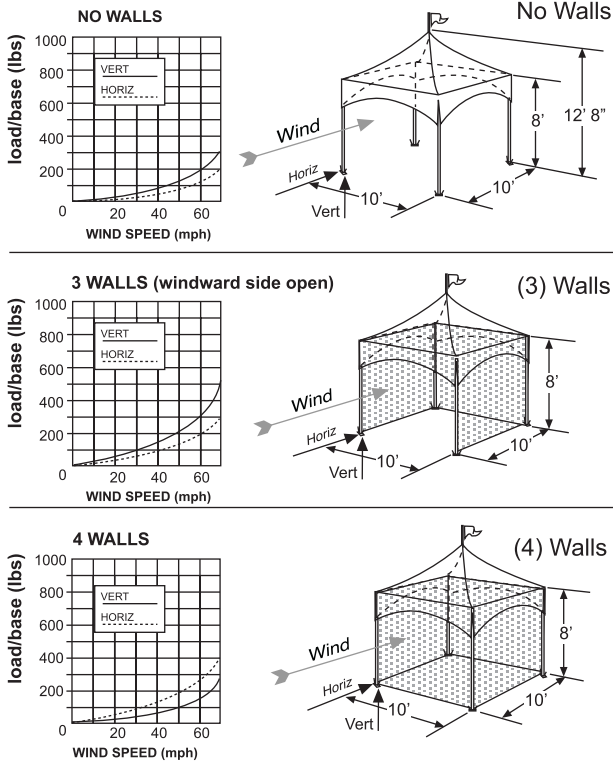

\*WIND SPEED - is the wind directly on the tent. The wind speed reported through the media is usually measured 33' above ground at a local airport weather station. Wind load on your tent may be effected considerably by topography, trees, buildings, fences and other adjacent roughness.

To increase anchorage and stability, guy ropes are recommended. Much of the anchor loading may be transferred from the post base to the guy anchors.



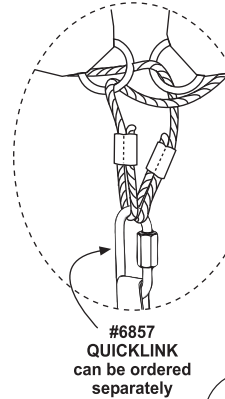

Guy ropes should be used in high wind areas.

**CAUTION:** Tension straps must be maintained tight and even for proper tensioning of the canopy fabric. The fabric must remain taut to avoid rain ponding.

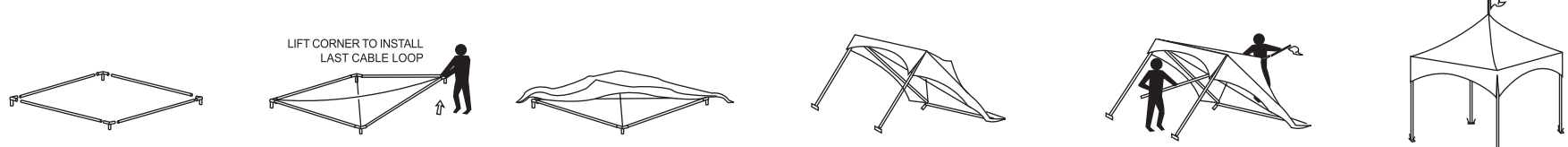
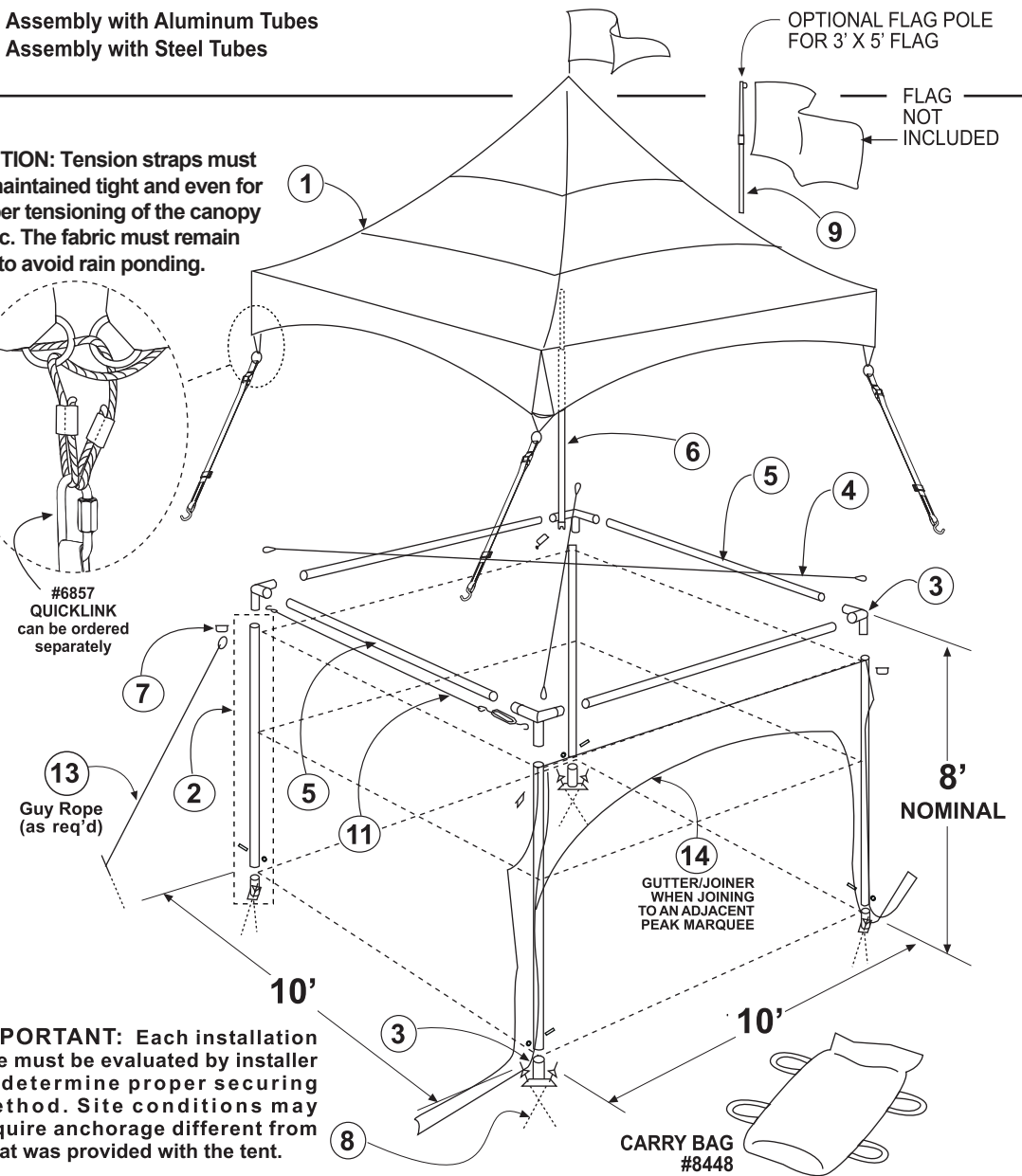

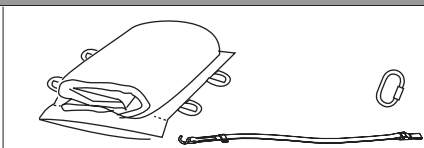
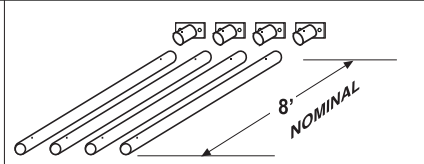
**IMPORTANT:** Each installation site must be evaluated by installer to determine proper securing method. Site conditions may require anchorage different from what was provided with the tent.

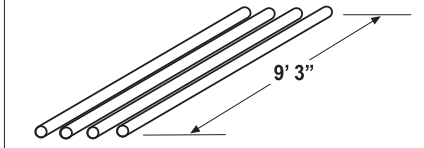
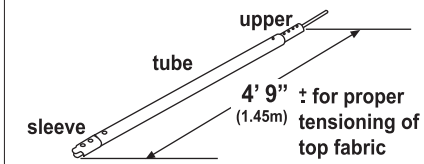

CANOPY		PART	PART NO.	QTY
1 TOP		Top	#10979	1
		Quicklink	#6857	4
		Tension Strap	#15050	4
FRAME				
2 POST ASSEMBLY		Base	#10514	4
		Post	alum #10591	4
		Post	steel #10590	4
		Bolts	#4093	4
	Nuts	#8369	4	
3 CORNER 90°		Corner 90°	#10628	4
4 CABLE		Cross Cable	#7296	2
5 EVE TUBES		Eve Tube		4
			alum #10630	
			steel #7161	
6 CENTREPOLE ASSEMBLY		Centrepole	#10963	1
7 LOCKPIN		Lock Pin	#7843	5

OPTIONS		PART NO.	QTY
8	STAKE 3/4" x 34"	#10666	8
9	FLAG POLE EXT.	#9523	1
10	DROP SHEET 10' x 10'	#10577	1
11	CABLE: 10' SLIDE WALL	#10675	AS REQ'D
12	BASE: ADJ. 24"	#11064	4
13	GUY ROPE 15' (5m)	#10689	AS REQ'D
14	GUTTER/JOINER 10' NOMINAL	#10960	AS REQ'D
REPAIR KIT for Vinyl Tops		#6844	-

Please call on our 800 line with any questions or concerns:



Toll-free: 1-800-661-6155  
Phone: (403) 279-7662  
Fax: (403) 236-2633  
Web: www.wssl.com  
Email: warner@wssl.com

9811 - 44th St, SE, Calgary, Alberta, Canada T2C 2P7